

Measuring the charging circuit

As an example for this task, the charging circuit of the Alfa Romeo Montreal is shown in fig 1. There is a separate voltage regulator and an amp meter in this circuit. A resistor has been placed in the D+ circuit. This resistor is often replaced by the alternator warning light. For more details, consult the complete diagram.

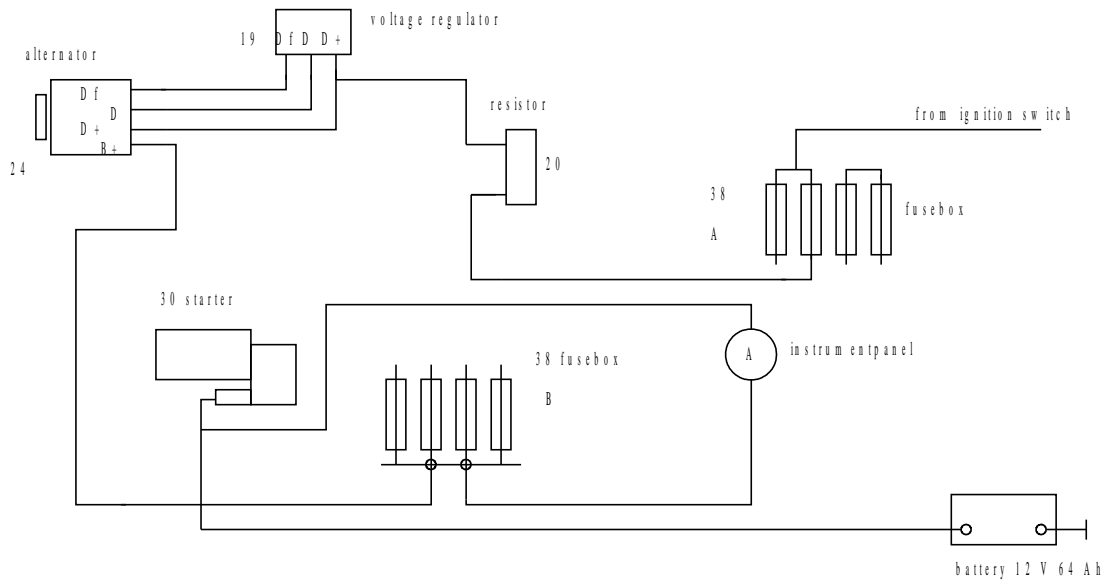

Fig. 1 Diagram of the Alfa Romeo Montreal charging circuit

Assignment

1. Using your demonstration car, check to see which terminals the alternator has. Use the demonstration car's electrical diagram to draw the charging circuit. Make sure you understand the circuit and can explain it. The diagram in figure 2 may help.
2. Measure voltage on B+, D+ and DF (if present):
 - a) On non-running engine with ignition switch off
 - b) On non-running engine with ignition switch on.
 - c) On running engine without extra electrical accessories in use
 - d) On running engine with lights and rear-window heater on.

Fill in the table below

		B+ (V)	D+ (V)	DF (V)
1	non-running engine with ignition switch off			
2	non-running engine with ignition switch on			
3	running engine without extra electrical accessories on			
4	running engine with lights and rear-window heater on			

3. Explain the measured values.

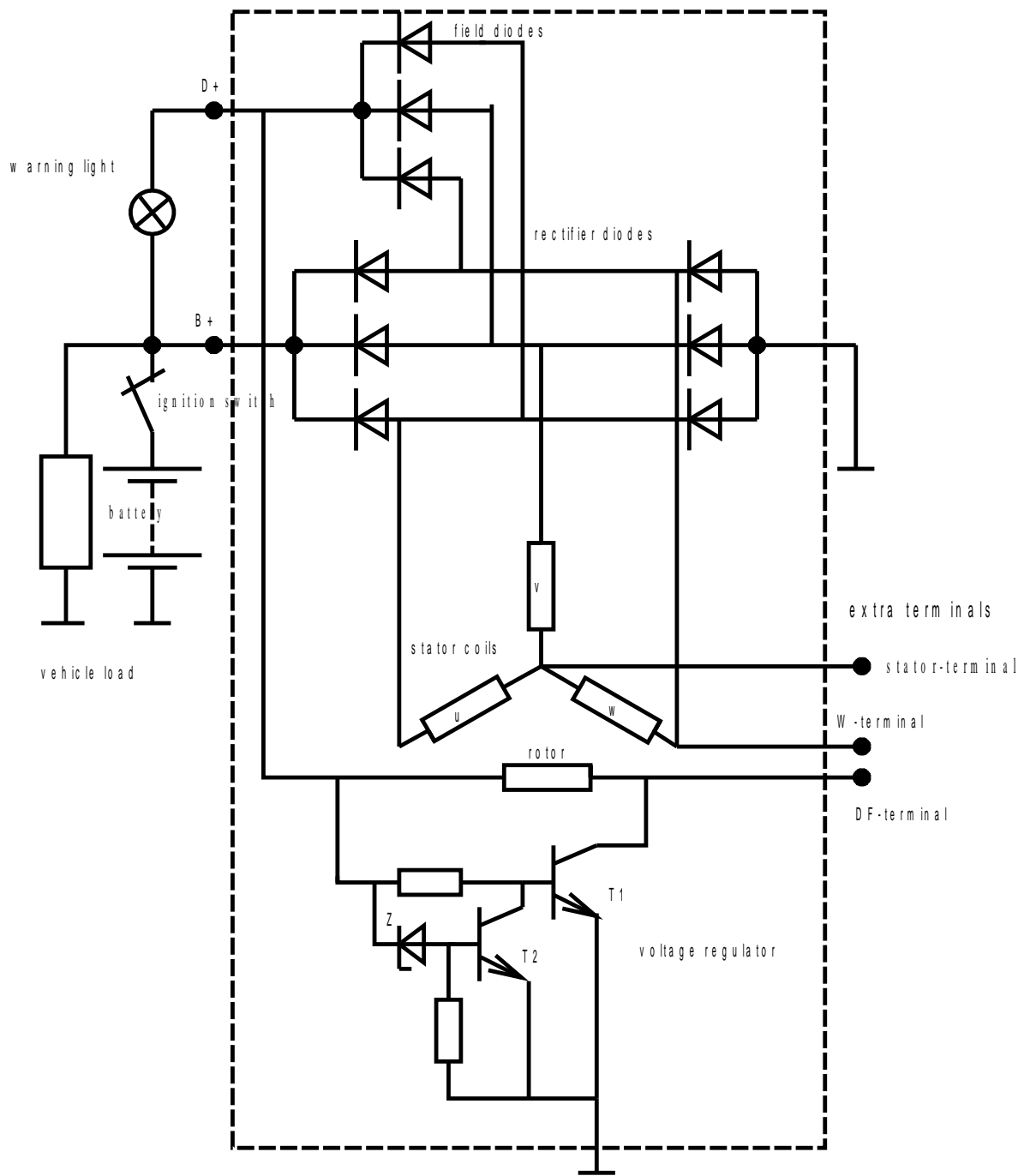

Fig. 2 Universal charging circuit diagram. Alternator with built-in electronic voltage regulator.