

Measuring the lighting circuit

As an example for this task, the lighting circuit of the Alfa Romeo Montreal is shown in figure 1. For more details, consult the complete diagram. The circuit is protected by a number of fuses.

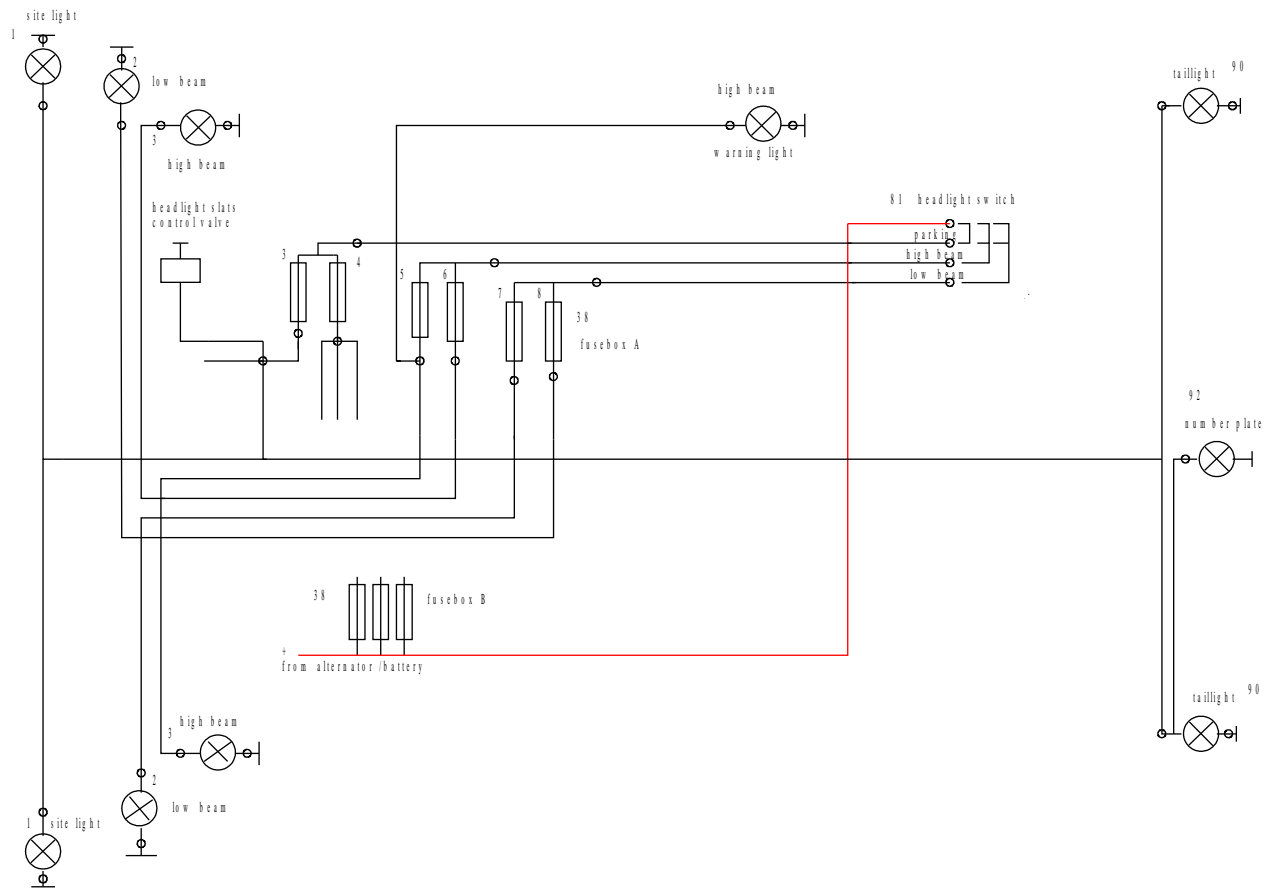

Fig. 1 Partial diagram of the lighting circuit

Assignment

1. Using your demonstration car, check to see how the lighting system is connected. Use the demonstration car's electrical diagram for this. Locate the various components.
2. Draw your own partial diagram of the lighting circuit and mark the measurement points for the task.
3. If desired, add simple malfunctions to the circuit on the car such as:
  - broken wire
  - poor ground connection
  - burnt-out fuse or wrong amp fuse
  - extra resistance at the switch

Make sure that the measurement points are accessible for the students.

As an example, figure 2 shows a number of measurement points in the circuit along with a number

of measurement tasks.

Here, the negative probe on the multimeter must be be connected to the negative pole of the battery.

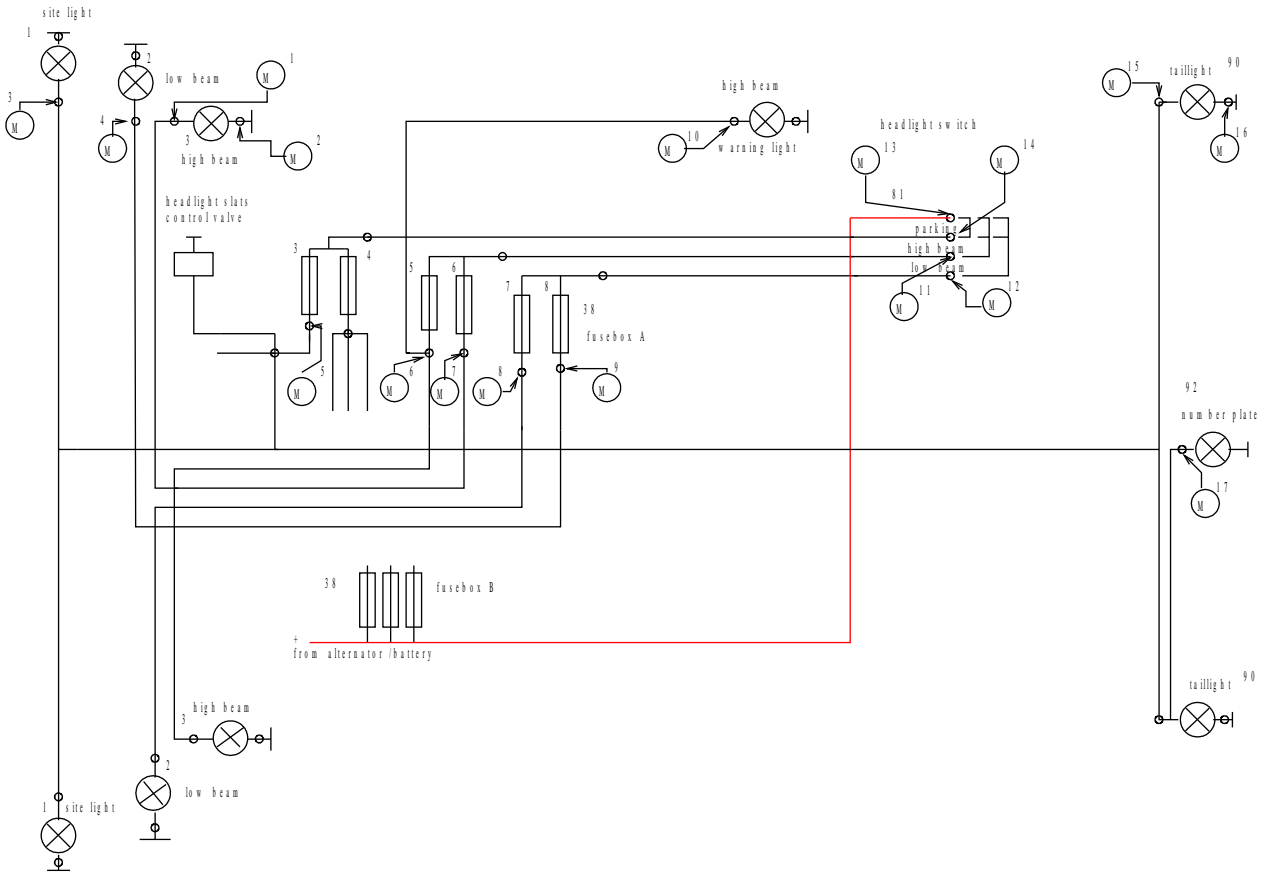

Fig. 2 Lighting circuit diagram with possible measurement points

**Measurement tasks**

Fill in the chart below with the voltmeter readings in the following situations:

- situation 1: light switch is on 'side lights'
- situation 2: light switch is on 'low beam'
- situation 3: light switch is on 'high beam'

	M1	M2	M3	M4	M5	M6	M7	M8	M9	M10	M11	M12	M13	M14	M15	M16	M17
situation 1																	
situation 2																	
situation 3																	

Conclusion:

The measured values in situation 1 are normal / abnormal  
If they are abnormal, give a possible cause.

The measured values in situation 2 are normal / abnormal  
If they are abnormal, give a possible cause.

The measured values in situation 3 are normal / abnormal  
If they are abnormal, give a possible cause.